

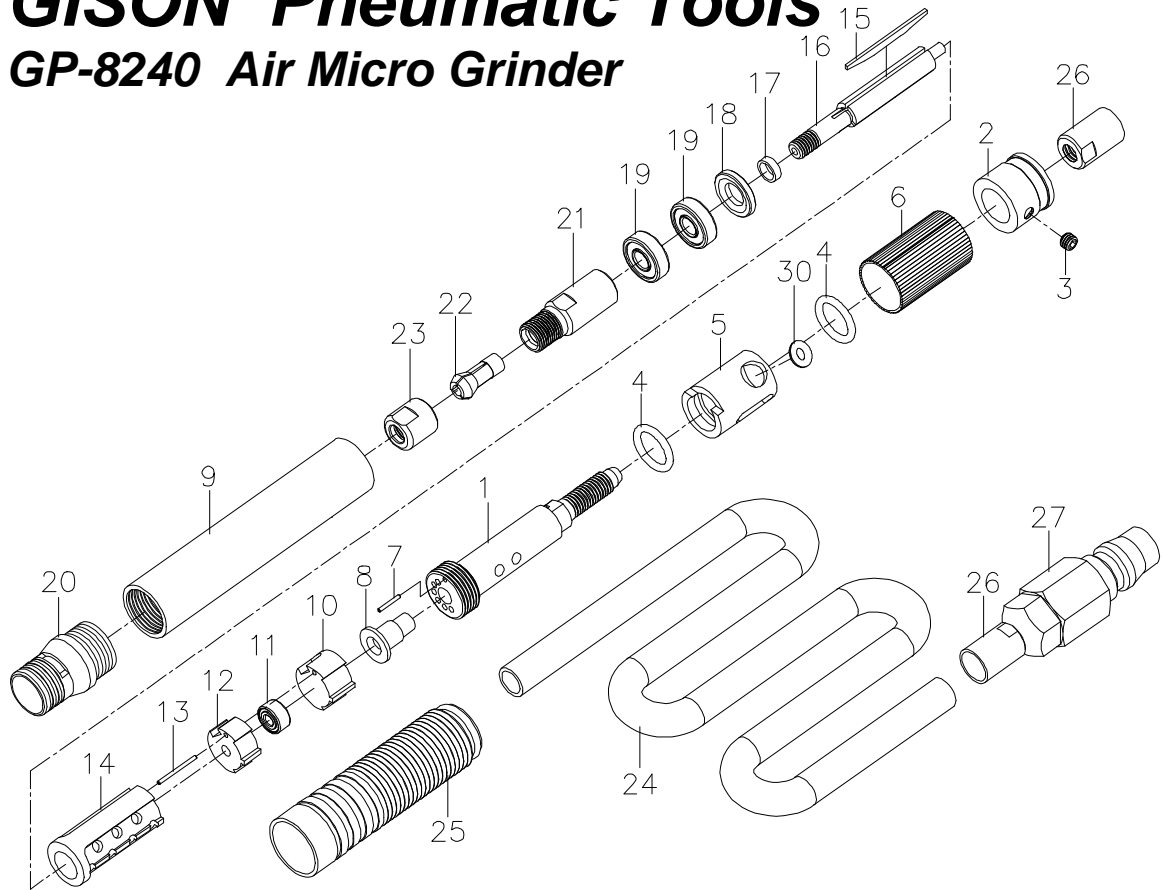

# GISON Pneumatic Tools

## GP-8240 Air Micro Grinder



### PARTS LIST

✦ : Consuming Part

Item No.	Part No.	Description	Qty.	Item No.	Part No.	Description	Qty.
1	8240-01	Air Intake Tube	1	16	8240-16	Rotor	1
2	8240-02	Rear End Holder	1	17	8240-17	Lateral Disc	1
3	8240-03	Screw	1	18	8240-18	Spacer	1
✦ 4	8240-04	O-Ring	2	✦ 19	8240-19	Ball Bearing	2
5	8240-05	Bushing	1	20	8240-20	Front Pipe	1
6	8240-06	Sliding Knob	1	21	8240-21	Chuck Stand	1
7	8240-07	Pin	1	✦ 22	8240-22	Collet	1
8	8240-08	Intake Steel Tube	1	23	8240-23	Clamping Nut	1
9	8240-09	Sleeve	1	24	8240-24	Air Hose (150 cm)	1
10	8240-10	Intake Plate	1	25	8240-25	Muffler Tube (40 cm)	1
✦ 11	8240-11	Ball Bearing	1	26	8240-26	Hose Ring	2
12	8240-12	Bearing Plate	1	27	8240-27	Inlet Connector	1
13	8240-13	Pin	1	30	8240-30	O-Ring	1
14	8240-14	Cylinder	1	31	8240-31	Spanner	2
✦ 15	8240-15	Rotor Blade	3				

**Application:** Ideal for grinding metal model, grinding the teeth of model, machine processing, engrave wood, gold processing and parts processing.

**Please read follows carefully before operating:**

1. Avoid heavy power impact to damage the precious Front Chuck.
2. To get the Abrasive Wheel tighten, please use wrench to turn reverse side everytime before operation.
3. Before operation, please be sure the Rotary Mounted Point is straight.
4. Always wear Safety Goggles to guard against eye injury cause be flying particles.
5. Suggest to use light density, non-detergent lubricant oil (i.e. #60).
6. Applicable to air working pressure 0~90 psig, regular speed: **54,000 RPM.**

**Maintenance:**

Do not try disassemble an airmotor by yourself, because it requires skillful person to maintain the tools. Repairing cost will be charged even it is during a term of gurantee, if the tool exposed rust or no trace of lubricant on a cylinder during the course of normal repair.

**Ball Bearings:**

A proper break in operation given to a new grinder during its initial use with such low pressure as 50~55 psi for the first 2~3 hours will favor to the grinder for its longer span of service afterwards.