

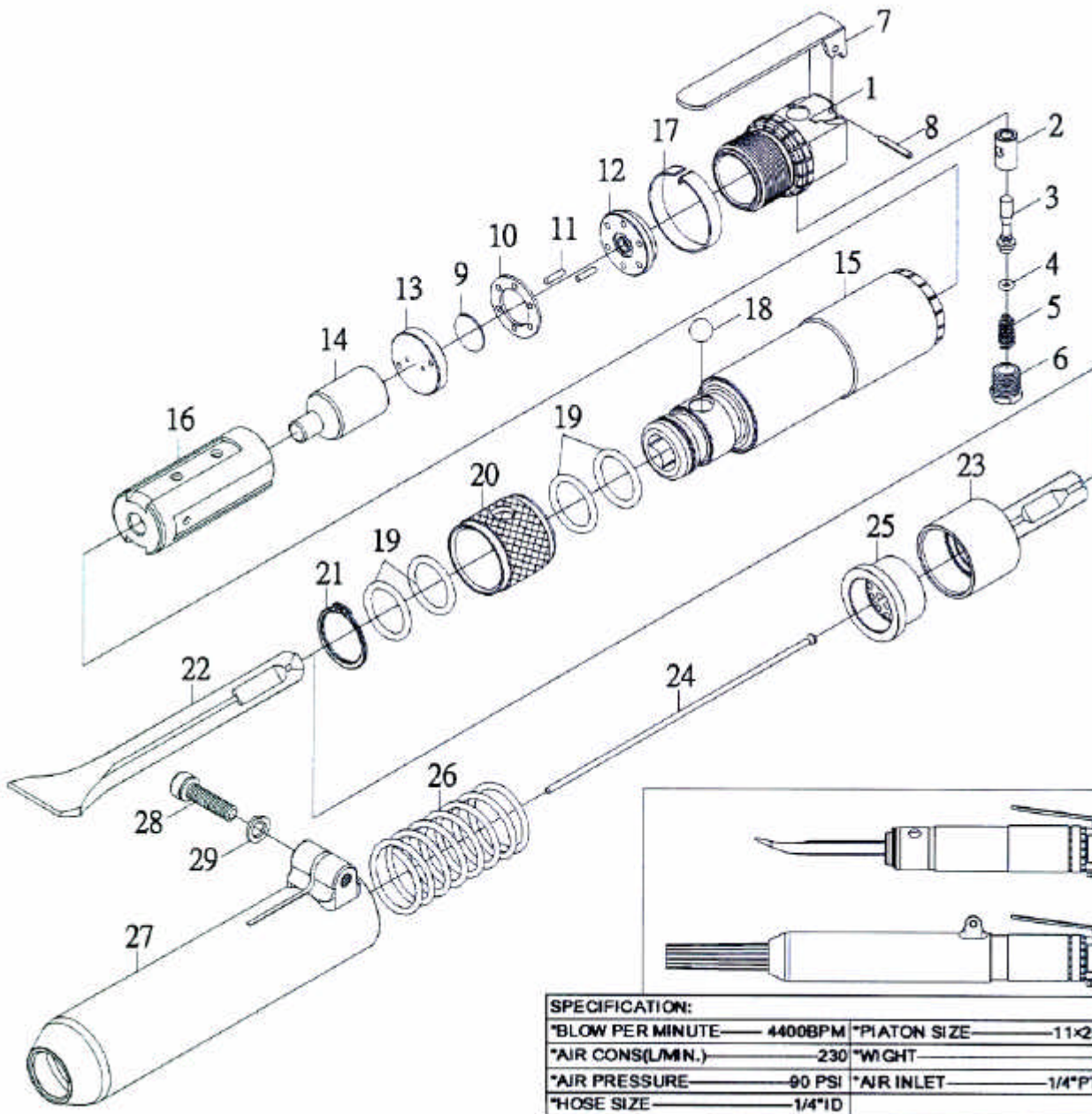

GISON Pneumatic Tools

GP-851E Air Needle Scaler & Flux Chipper(2-in-1)



SPECIFICATION:			
*BLOW PER MINUTE	4400BPM	*PISTON SIZE	11x25x50.5
*AIR CONS(L/MIN.)	230	*WIGHT	2.7KG
*AIR PRESSURE	90 PSI	*AIR INLET	1/4"PT(NPT)
*HOSE SIZE	1/4"ID		

PARTS LIST

◆ :Consuming Part

Item No.	Part No.	Description	Qty.	Item No.	Part No.	Description	Qty.
1	851E01	Cylinder Cap	1	16	851E16	Piston Sleeve	1
2	851E02	Throttle Bushing	1	17	851E17	Lock Ring	1
3	851E03	Throttle Rod	1	18	851E18	Ball (SB-7/16)	1
◆ 4	851E04	O-Ring	1	19	851E19	O-Ring (P24)	4
5	851E05	Spring (8x16)	1	20	851E20	Chisel Cover	1
6	851E06	Throttle Cap	1	21	851E21	Snap Ring (STW30)	1
7	851E07	Throttle Lever	1	22	851E22	Chisel	1
8	851E08	Spring Roll Pin (3x22)	1	23	851E23	Needle Shank	1
9	851E09	Main Valve	1	24	851E24	Needle (19 pcs / set)	1 set
10	851E10	Main Valve Case	1	25	851E25	Needle Flange	1
11	851E11	Pin (2.8x11)	2	26	851E26	Spring (38x83)	1
12	851E12	Lower Main Valve	1	27	851E27	Needle Cover	1
13	851E13	Upper Main Valve	1	28	851E28	Hex. Socket Bolt (M8x20)	1
◆ 14	851E14	Piston	1	29	851E29	Spring Washer (M8#2)	1
15	851E15	Cylinder Body	1				